

HIGH WATER/ FLOOD RESCUE TRUCKS

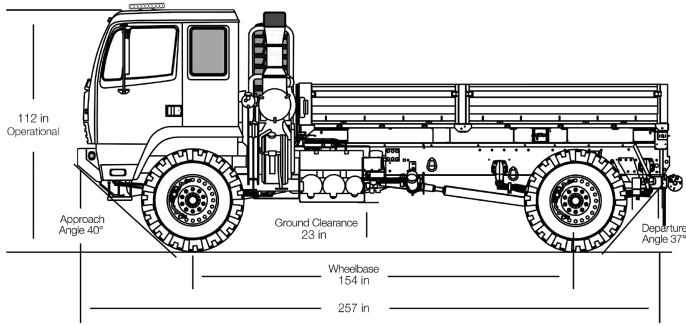

50-INCH WATER FORDING CAPABILITY - 4X4 & 6X6 MODELS - TOP SPEED 74 MPH

Acela Truck Company, manufacturer of North America's most capable trucks, now offers purpose-built High Water/Flood Rescue Trucks in both 4x4 and 6x6 variations of its Monterra™ line of truck chassis. With 47-inch tires, 23-inches of ground clearance, waterproof starter, waterproof alternator and a proprietary 50-inch water fording capability, there is no other modern truck platform that can compete when it comes to reliable and safe operations in flood waters. Available models and customizable configurations can safely transport up to 27 seated passengers (incl. driver) with ample room and payload for pets, personal property and rescue gear. Monterra flood rescue trucks can be used for virtually any disaster response such as tornadoes, hurricanes, blizzards, and earthquakes, easily traveling over or through large debris, sand and mud or double as brush/wildland fire engines, Urban Search and Rescue (USAR) support vehicles, cargo haulers and SAR/SWAT team troop carriers, in any rural or urban environment. Monterras come standard with a bumper to bumper parts and labor warranty.



4x4 - Up to 17 Seated Passengers

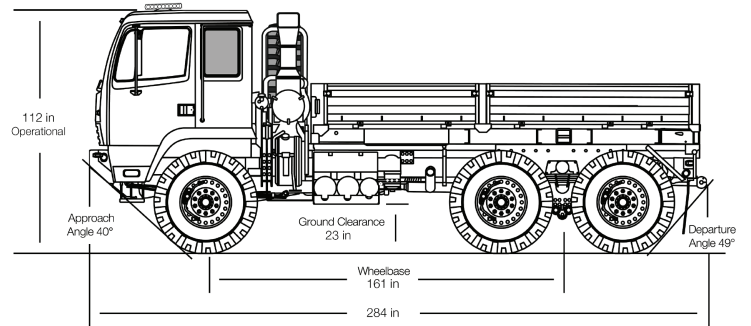

6x6 - Up to 27 Seated Passengers

KEY SPECIFICATIONS

- ◆ 50" Water Fording Capability
- ◆ 4x4 & 6x6 Models
- ◆ 17-27 Passengers (Including Driver)
- ◆ All-Wheel-Drive
- ◆ Up to 74 MPH Top Speed
- ◆ 47" Tires
- ◆ 23" Ground Clearance
- ◆ 330 HP/Allison Automatic Transmission
- ◆ Waterproof Starter and Alternator

*SEE FULL MONTERRA™ SPECIFICATION SHEET

POPULAR OPTIONS

- ◆ NFPA Warning Lighting
- ◆ Scene Lighting
- ◆ Liftgates
- ◆ Wheelchair Tie-Downs
- ◆ Canopies
- ◆ Stairs
- ◆ Rescue Boat Storage/Rack Systems



Acela Truck Company

1-800-940-0508

info@acelatruck.com

This document gives only a general description of the product(s) or services and except where expressly provided otherwise shall not form part of any contract. From time to time, changes may be made in the products or the conditions of supply. Acela Truck Company reserves the right to change product specifications without prior notice. Photos, descriptions and/or drawings may represent optional equipment. All Rights Reserved

